

Robotic Coupling

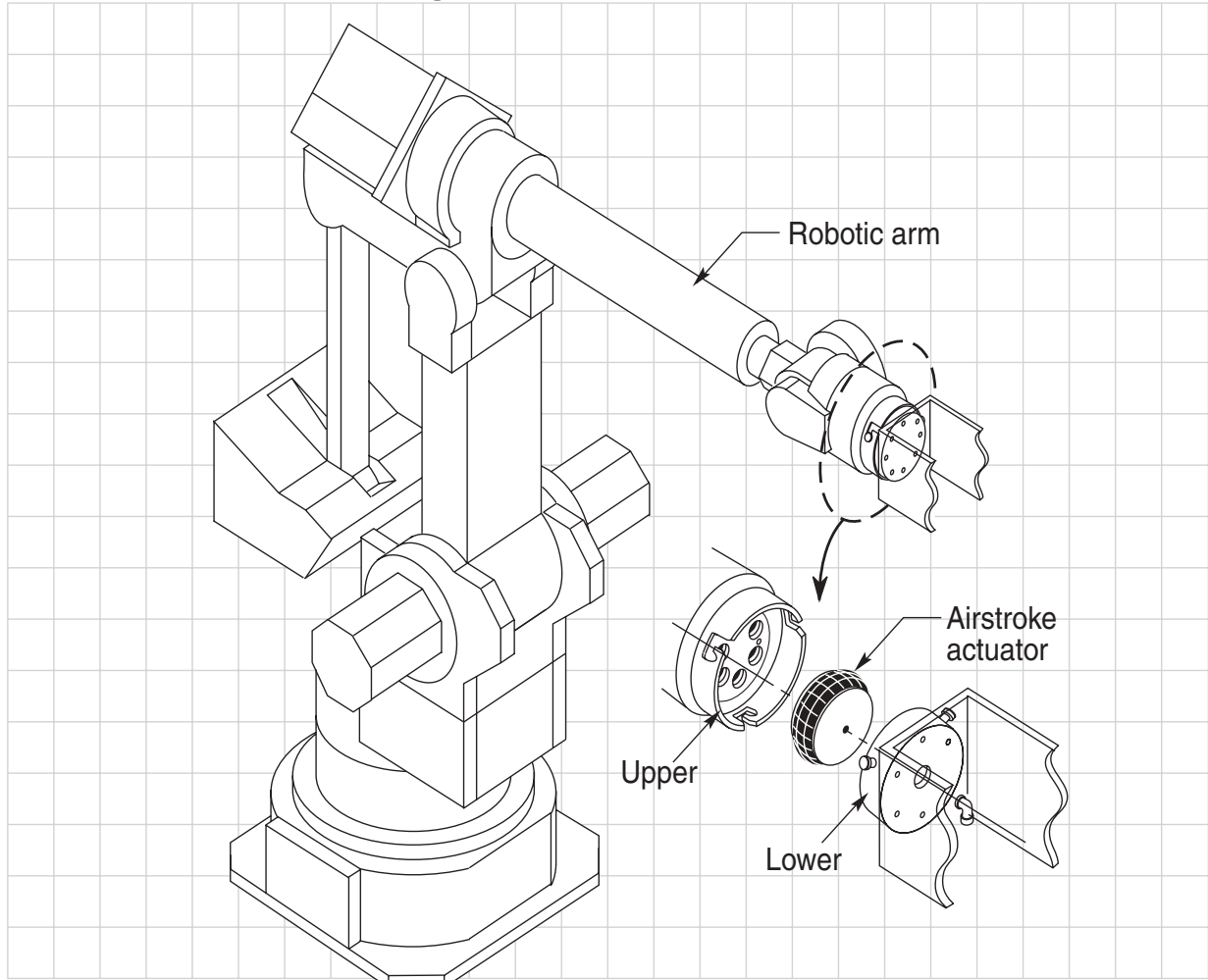

Problem

Spring clutch mechanisms are used between the “joint” and end tooling of robotic systems. In the event of a “collision,” the mechanism allows compliance and an electric switch shuts down the robot. To assure proper operation, the mechanisms require constant and labor-intensive screw adjustments.

Solution

Utilize an Airstroke actuator between the “joint” and end tooling to provide the force and multi-directional compliance when needed during a collision.

Benefit

Instead of tedious screw adjustments, the actuator can be quickly and incrementally adjusted with a pressure regulator. Replacing and changing end tools to perform different robotic functions is also possible.